



Tracer™ Controllers

**Tracer AH541 Version 2
Air-Handler Controller**





Overview

The Tracer AH541 air-handler controller is available for field installation on constant-volume and variable-air-volume (VAV) air handlers. The Tracer AH541 controller provides the same functionality as the Tracer AH540 controller, which is factory-installed on Trane air handlers.

Applications

The Tracer AH541 controller supports a variety of air-handler configurations that conform to the LonMark[®] Space Comfort Controller (SCC) profile or the Discharge Air Controller (DAC) profile. Possible configurations include:

- Cooling-only unit
- Heating-only unit without bypass
- Heating-only unit with bypass
- Cooling and heating unit (coils in either order) without bypass
- Heating and cooling unit (coils in this order) with bypass for the heating coil
- Heating and cooling unit (coils in this order) with bypass for both coils
- Heating cooling changeover (single coil)
- Heating cooling changeover (single coil) with electric heat

Heating options

- Hydronic
- Steam
- Electric (staged)

Cooling options

- Hydronic
- DX (up to four stages)

Product models

The following Tracer AH541 models are available:

- Enclosure with door-mounted operator display
- Enclosure without operator display
- Frame-mounted controller (termination board and circuit board in a plastic frame assembly)

The following operator-display models are available:

- Stand-alone operator display
- Portable operator display
- Door-mounted operator display retrofit kit

For more detailed information on each model, see "Product models" on page 4.

[™] [®] The following are trademarks or registered trademarks of their respective companies: LonTalk and LonMark from Echelon Corporation; Rover, Tracer, and Tracer Summit from American Standard Inc.

Contents

Overview	2
Applications	2
Product Models	2
Product Models	4
Tracer AH541 models	4
Operator display models	4
Features	6
Duct static-pressure control	6
Space dehumidification	6
Filter status	6
Generic binary input	6
Manual output test	6
Emergency override	6
System integration	6
Operator display	6
Network architecture	7
Inputs and outputs	8
Enclosure interior	9
Dimensions	10
Specifications	11
Power requirements	11
Power consumption	11
Operating environment	11
Storage environment	11
Enclosure	11
Weight	11
Dimensions	11
Minimum clearances	11
Mounting	11
Operator interface	11
Time clock	11
Battery	11
Agency listings/compliance	11



Product models

Tracer AH541 models

Several Tracer AH541 models are available. These models are illustrated in Figure 1 on page 5. For dimensions and other information, refer to "Specifications" on page 11.

Tracer AH541 in a NEMA-1 enclosure

The Tracer AH541 with enclosure consists of a termination board, a circuit board, and a line-to-low voltage transformer mounted in an enclosure compliant with National Electrical Manufacturers Association (NEMA) type-1 standards. The enclosure has a hinged door and plenty of room for input and output wiring. The complete assembly is UL-listed.

The controller is available in a NEMA-1 enclosure with or without an operator-display touch screen mounted in the door. Enclosures without displays can be upgraded at any time with a stand-alone operator display or a retrofit enclosure door with a display.

Frame-mounted Tracer AH541

The frame-mounted Tracer AH541 consists of a circuit board and a termination board mounted in a two-piece modular frame assembly. This modular design allows the circuit board to be stored at a safe location while installation and wiring are completed. The frame-mounted Tracer AH541 can be mounted in existing equipment or enclosures.

Operator display models

Operator-display touch screens are available as an option for all Tracer AH541 models. The operator-display options are illustrated in Figure 2 on page 5.

Stand-alone operator display

The stand-alone operator display is designed for permanent local connection to a Tracer MP580/581 or AH540/541 controller (Version 1.5 or higher). The stand-alone operator display includes a 7-day time clock to provide scheduling capabilities for the associated controller. The 10-foot (3 meter) connector cable can be extended up to 150 feet (46 meters) with additional wire.

Portable operator display

The portable operator display is designed for temporary connection to a Tracer MP580/581 or AH540/541 controller (Version 1.5 or higher). The operator-display touch screen is mounted in a resin enclosure, which is placed in a padded, protective carrying case. A ten-foot (three meter) connector cable is included.

Retrofit door-mounted operator display

The retrofit door-mounted operator display is a complete enclosure door with an operator-display touch screen mounted in it. Use this kit to upgrade an enclosure that does not have an operator display. The operator display works with any Tracer MP581 or Tracer AH541 controller.

Figure 1: Tracer AH541 models

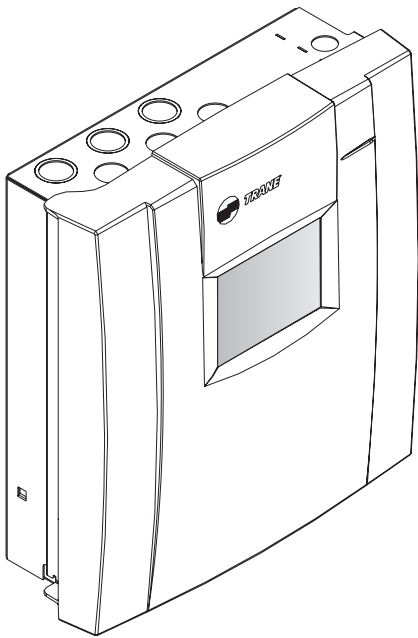

Tracer AH541 with optional operator display

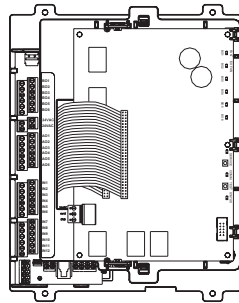

Frame-mounted Tracer AH541

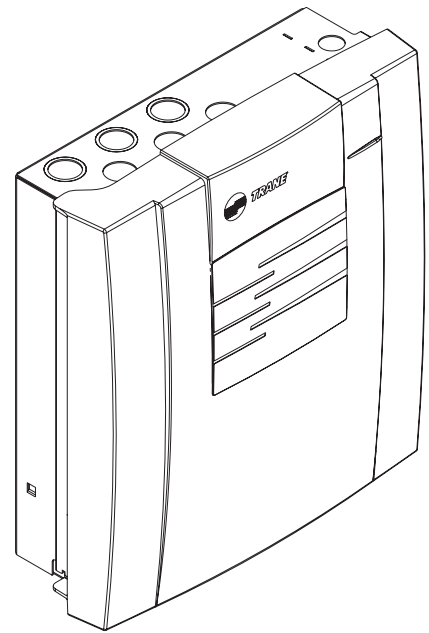

Tracer AH541 without operator display

Figure 2: Operator display models

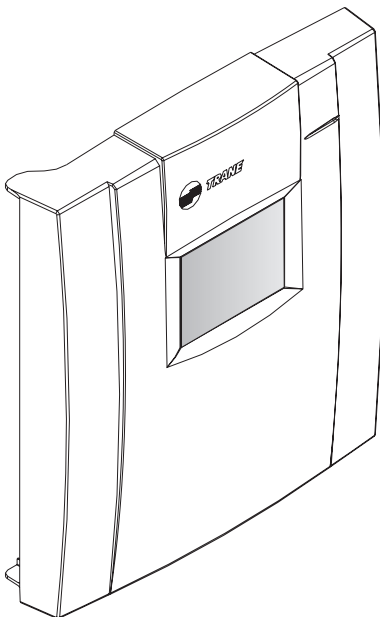

Retrofit door-mounted operator display



Portable operator display in carrying case

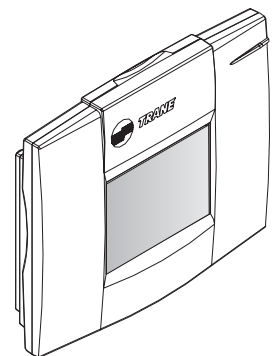

Stand-alone operator display

Features

Duct static-pressure control

In the variable-air-volume (VAV) mode, the Tracer AH541 controls duct static pressure. When the supply fan is on, the controller compares the duct static-pressure input to the duct static setpoint and adjusts the supply fan speed accordingly. If the controller does not receive a valid duct static-pressure value, it generates a diagnostic and shuts down the unit.

Space dehumidification

The AH541 controller provides both occupied and unoccupied dehumidification control for space temperature control applications. The dehumidification control sequence is allowed on unit configurations with hydronic or DX cooling and hydronic or electric reheat. A hardwired or communicated space relative humidity value is required.

Filter status

The Tracer AH541 can monitor the filter status in one of two ways:

- By tracking the cumulative run hours of the supply fan. When the run time expires, the controller sends a notice to the operator display and Tracer Summit system that maintenance is recommended.
- From a positive-proof switch wired to binary input IN11.

Generic binary input

The occupancy binary input can be configured as a generic binary input for use as a network point with the Tracer Summit system. The generic input does not affect unit operation.

Manual output test

The manual output test allows a service technician to quickly check all outputs for proper operation. Each press of the Test button on the circuit board steps through the outputs, energizing them in succession.

Emergency override

The emergency override mode can be selected from the Rover service tool or the Tracer Summit system. The operator can use this mode to pressurize, depressurize, or purge the air from a building space by overriding the outdoor-air damper, supply fan, and exhaust fan.

System integration

The Tracer AH541 controller communicates using the LonTalk communication protocol and a TP/FT-10 communication channel. The controller can be configured to conform to the LonMark® Space Comfort Controller (SCC) profile or the Discharge Air Controller (DAC) profile.

Operator display

The operator-display touch screen has a common look and feel across Tracer controllers. This similarity simplifies training and enhances operator efficiency in buildings with multiple Tracer controllers. Because the operator display has no buttons, keyboard, or mouse, it is easy to learn and use.

The operator display is designed for connection to a Tracer MP580/581 or Tracer AH540/541 controller (Version 1.5 or higher).

Available models

The operator display is available in portable, stand-alone, and door-mounted models, or as a retrofit door-mounted kit. The operator-display models are illustrated in Figure 2 on page 5.

Multiple-language support

The operator display supports multiple languages, which can be selected through the Rover service tool. English, Spanish, and French-Canadian (Version 2.0 or higher) are currently available.

Navigation

Navigation of the touch screen is intuitive, with logical paths to find information in the fewest steps. The Home screen, shown in Figure 3, appears on power-up, and can be reached from any page by pressing the Home button. The Home screen menu shows information about the controller and has buttons to access common tasks and information.

Figure 3: Home screen

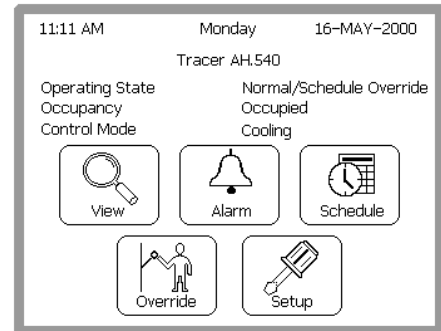

From the touch screen, the operator can:

- Change setpoints and timer values
- Calibrate the space sensor value
- View input/output and communication status
- View and reset alarms
- Schedule 7-day start /stop times and exception schedules
- Override schedules and outputs
- Perform a manual output test
- Balance the hydronic system

Network architecture

Tracer AH541 controllers can operate as stand-alone controllers, as part of a peer-to-peer network, or as part of a Tracer Summit building automation system (see Figure 4).

Figure 4: Tracer AH541 controller as part of a building automation system with Trane LonTalk controllers

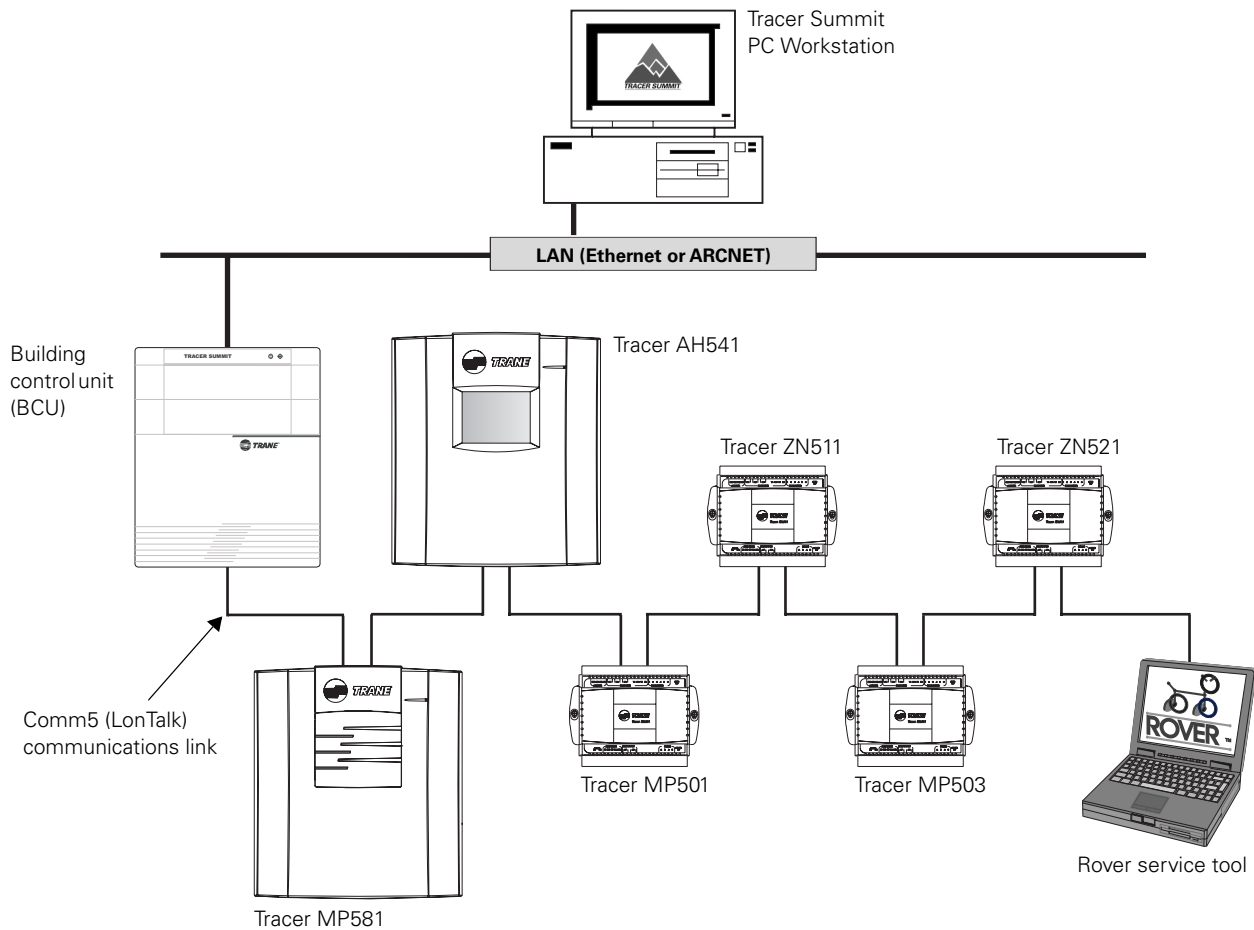

Inputs and outputs

The Tracer AH541 controller has the following inputs and outputs (illustrated in Figure 5):

- Six binary outputs
- Five analog outputs
- Six analog inputs
- Six binary inputs
- Duct static-pressure input
- Universal analog input on main controller

The inputs and outputs must be used for the functions listed in Figure 5. For example, an outside-air temperature sensor can be connected only to terminal IN5.

Note that analog output 6 (AO6) is not used.

Figure 5: Wiring diagram

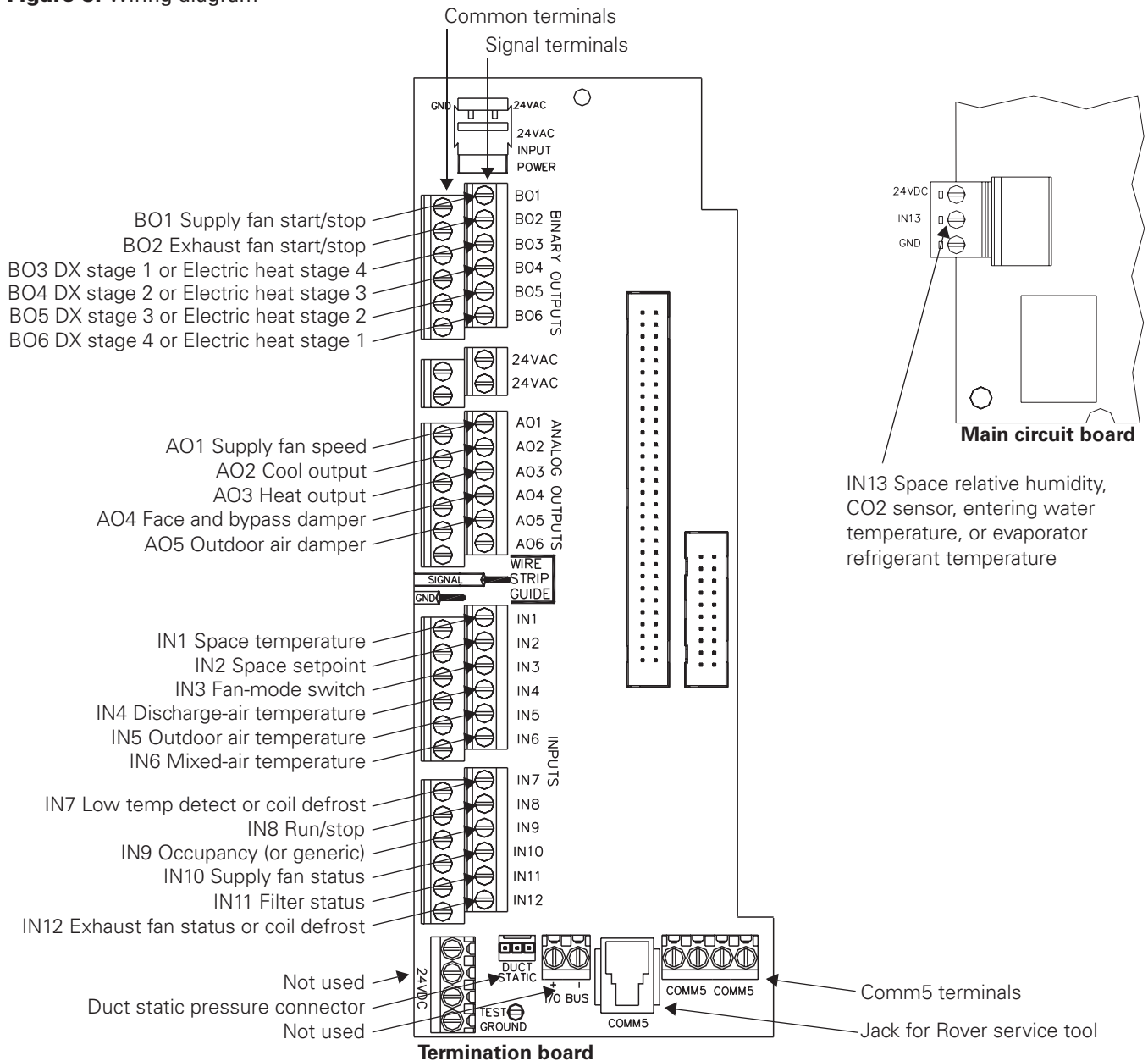

Enclosure interior

Figure 6 shows the interior of the Tracer AH541 NEMA-1 enclosure. Significant space is available for wiring inputs and outputs. Wires should be routed over the optional pressure sensor.

Figure 6: Tracer AH541 enclosure interior

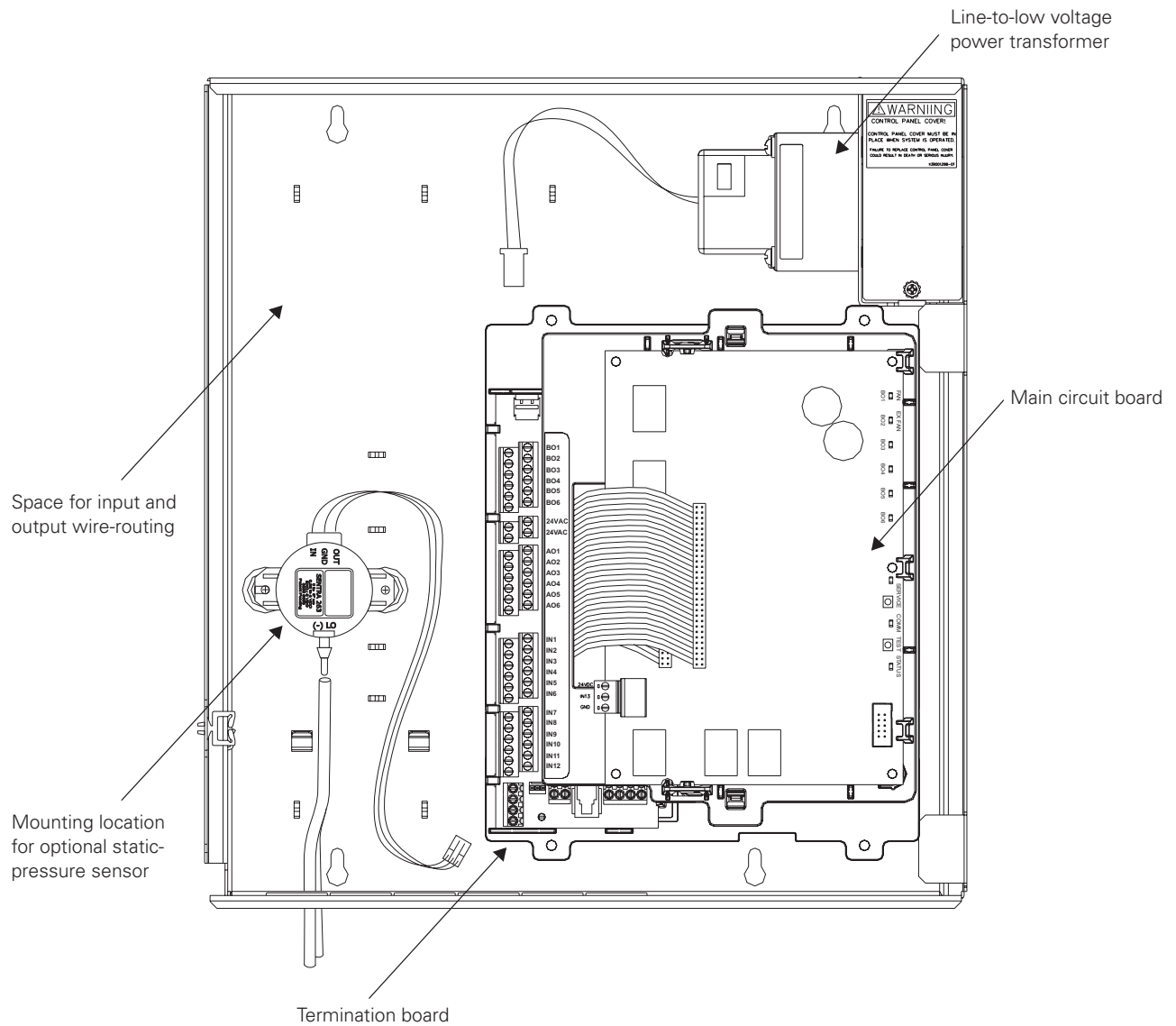

Dimensions

Figure 7: Tracer AH541 enclosure dimensions

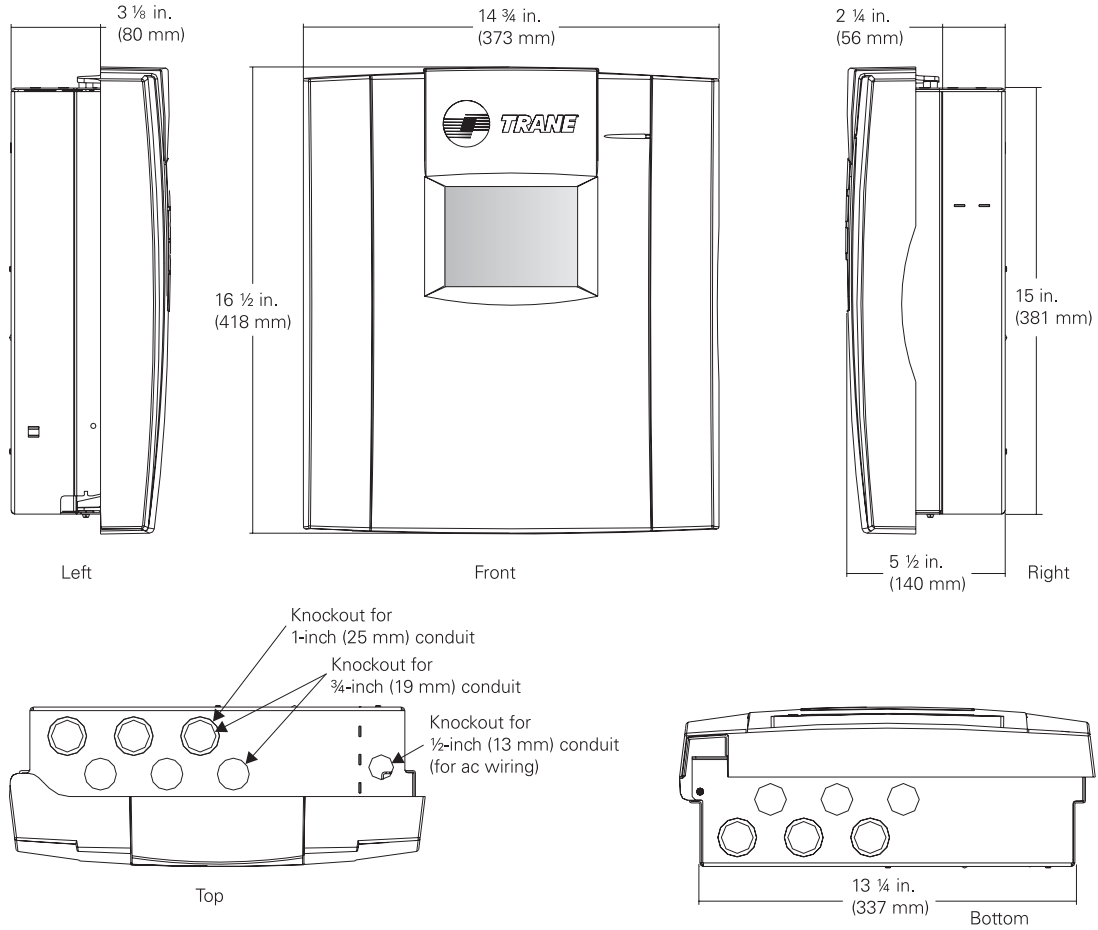
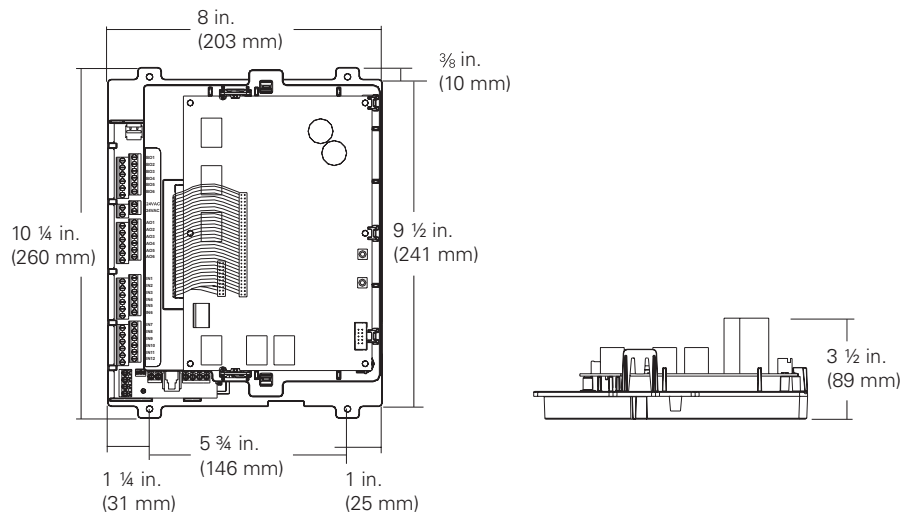

Figure 8: Frame-mounted Tracer AH541 dimensions



Specifications

Power requirements

Nominal rating: 24/120/230 Vac;
50/60 Hz; 1 phase

Voltage utilization range
24 Vac (frame-mounted): 19–30 Vac
120 Vac nominal: 98–132 Vac
230 Vac nominal: 196–264 Vac

Power consumption

Tracer AH541 controller: 21 VA
Optional operator display: 7 VA

Operating environment

Temperature
Without display: From –40°F to 158°F
(–40°C to 70°C)
With display: From 32°F to 122°F
(0°C to 50°C)

Humidity: 10–90% non-condensing

Storage environment

Temperature
Without display: From –40°F to 185°F
(–40°C to 85°C)
With display: From –13°F to 149°F
(–25°C to 65°C)

Humidity: 5–95% non-condensing

Enclosure

Enclosure compliant with National
Electrical Manufacturers Association
(NEMA) type-1 standards

Weight

With NEMA-1 enclosure: 15 lb (7 kg)
Frame-mounted: 2 lb (1 kg)

Dimensions

Tracer AH541 NEMA-1 enclosure
16 ½ in. × 14 ¾ in. × 5 ½ in.
(418 mm × 373 mm × 140 mm)
Frame-mounted Tracer AH541
10 ¼ in. × 8 in. × 3 ½ in.
(260 mm × 203 mm × 89 mm)

Minimum clearances

NEMA-1 enclosure
12 in. (30 cm) top, bottom, and right
24 in. (60 cm) left
36 in. (90 cm) front

Frame-mounted
½ in. (1.3 cm) top, right, and front
6 in. (15 cm) left (for I/O wiring)
3 in. (8 cm) bottom (for
communications wiring)

Mounting

NEMA-1 enclosure: wall-mounted with
#10 (5 mm) screws

Frame-mounted: #8 (4 mm) screws

Operator interface

Video graphics adapter (VGA) backlit
liquid crystal display (LCD) with touch
screen; 4.5 in. × 3.4 in. (115 mm ×
86 mm) viewable area; resolution of
320 × 240 pixels

Time clock

Included with operator display; crystal
controlled, super-capacitor backed

Battery

Not required—backed by super capacitor
for seven days under normal operating
conditions; all other programs backed by
non-volatile memory

Agency listings/compliance

UL and C-UL
UL 916 Energy Management
CUL C22.2 No. 205-M1985 Signal
Devices

FCC approved: CFR 47, Part 15,
Subpart A, Class A

CE Conformance
Emissions
EN55022 Class B
EN61000-3-2
EN61000-3-3

Immunity
EN50082-2 Industrial



Trane
A business of American Standard Companies
www.trane.com

For more information, contact your local Trane office or e-mail us at comfort@trane.com

Literature Order Number	BAS-PRC013-EN
File Number	PLES-BAS-000-PRC013-0204
Supersedes	BAS-PRC013 January 2002
Stocking Location	Inland

Trane has a policy of continuous product and product data improvement and reserves the right to change design and specifications without notice.